

NIKO
HEATING

HEATING COLLECTION

In tune with your lifestyle





Niko Heating have a collection of high quality heating products and plumbing fittings, carefully chosen for Irish consumers. The Heating Collection has been carefully selected based on over thirty years of Customer Service, Quality, and Product Knowledge.

Our comprehensive radiator range combined with nationwide delivery and backup make us the number one choice for the Heating and Plumbing trade in Ireland. We distribute our products throughout Ireland via a network of selected quality stockists.

Our Ranges

| | |
|--|-----------|
| Revive Column Vertical & Horizontal | 04 |
| Valerie Vertical Flat Panel | 08 |
| Hayley Horizontal Flat Panel | 10 |
| Towel Warmers Designer radiators to suit your home | 12 |
| Mariah Dual Column Mirror Radiator | 20 |
| Rua Designer Flat Panel | 22 |
| Sara Vertical Panel Radiators | 24 |
| Imas Compact Radiator Range | 26 |
| Valves | 32 |
| Technical Specifications | 36 |

REVIVE

Column Vertical & Horizontal



REVIVE 2 COLUMN VERTICAL

A collection of column radiators made to the highest standards to provide complete customer satisfaction.

These radiators are stylish replacements for standard panel radiators, and can be arranged in similar positions, with minimum disruption.

The White and Black models fit timelessly in both contemporary and period interiors, while the Raw Metal design adds a striking touch to any modern or retro interior.

| | Colour | Height (mm) | Width (mm) | BTU | Watts | Pipe Centres | |
|-------------|-----------|-------------|------------|------|-------|--------------|---------|
| U2150-8 | White | 1500 | 398 | 2839 | 832 | 488 | €384.87 |
| U2180-8 | White | 1800 | 398 | 3385 | 992 | 488 | €436.53 |
| U2180-10 | White | 1800 | 490 | 4231 | 1240 | 580 | €552.27 |
| U2200-8 | White | 2000 | 398 | 3767 | 1104 | 488 | €488.19 |
| U2200-10 | White | 2000 | 490 | 4709 | 1380 | 580 | €643.17 |
| U2180-10-RM | Raw Metal | 1800 | 490 | 4231 | 1240 | 580 | €643.17 |
| U2200-10-RM | Raw Metal | 2000 | 490 | 4709 | 1380 | 580 | €678.05 |
| U2180-10-BK | Black | 1800 | 490 | 4231 | 1240 | 580 | €643.17 |
| U2200-10-BK | Black | 2000 | 490 | 4709 | 1380 | 580 | €678.05 |

REVIVE 3 COLUMN VERTICAL

| | Colour | Height (mm) | Width (mm) | BTU | Watts | Pipe Centres | |
|-------------|-----------|-------------|------------|------|-------|--------------|-----------|
| U3200-10 | White | 2000 | 490 | 6244 | 1830 | 580 | €850.00 |
| U3200-10-RM | Raw Metal | 2000 | 490 | 6244 | 1830 | 580 | €1,095.00 |
| U3180-10 | White | 1800 | 490 | 5664 | 1660 | 580 | €850.00 |
| U3180-10-RM | Raw Metal | 1800 | 490 | 5664 | 1660 | 580 | €1,035.00 |



Raw Metal

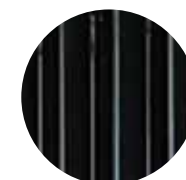

Black



White

VALVE RECOMMENDATION

Our valve recommendation is a 1/2" Bentley Thermostatic Radiator Valve Lock-Shield Pack in Black Nickel.

Code EV- B15BN

See our full valve section for more options - starting on page 32.





REVIVE 3 COLUMN HORIZONTAL

| | Colour | Height (mm) | Width (mm) | BTU | Watts | Pipe Centres | |
|-------------|-----------|-------------|------------|------|-------|--------------|-----------|
| U3060-13 | White | 600 | 628 | 2701 | 792 | 718 | €400.37 |
| U3060-19 | White | 600 | 904 | 3948 | 1157 | 994 | €542.43 |
| U3060-25 | White | 600 | 1180 | 5195 | 1523 | 1270 | €736.16 |
| U3060-32 | White | 600 | 1502 | 6649 | 1949 | 1592 | €916.97 |
| U3060-36 | White | 600 | 1686 | 7480 | 2192 | 1776 | €1,020.29 |
| U3060-13-RM | Raw Metal | 600 | 628 | 2701 | 792 | 718 | €477.86 |
| U3060-19-RM | Raw Metal | 600 | 904 | 3948 | 1157 | 994 | €658.67 |
| U3060-25-RM | Raw Metal | 600 | 1180 | 5195 | 1523 | 1270 | €865.31 |
| U3060-32-RM | Raw Metal | 600 | 1502 | 6649 | 1949 | 1592 | €1,097.78 |
| U3060-36-RM | Raw Metal | 600 | 1686 | 7480 | 2192 | 1776 | €1,226.93 |
| U3060-13-BK | Black | 600 | 628 | 2701 | 792 | 718 | €477.86 |
| U3060-19-BK | Black | 600 | 904 | 3948 | 1157 | 994 | €658.67 |
| U3060-25-BK | Black | 600 | 1180 | 5195 | 1523 | 1270 | €865.31 |
| U3060-32-BK | Black | 600 | 1502 | 6649 | 1949 | 1592 | €1,097.78 |
| U3060-36-BK | Black | 600 | 1686 | 7480 | 2192 | 1776 | €1,226.93 |

Note * Additional sizes available to order

Radiator Feet

Although radiator feet create the appearance of a free-standing radiator, they only support its weight, so you will still need to use the wall brackets supplied. Available in Black, Raw Metal and White. Height 100mm.



UCRFW €55.35
Revive Column Radiator Feet White (pack of 2 feet)



UCRFBK €79.95
Revive Column Radiator Feet Black (pack of 2 feet)



UCRFRM €79.95
Revive Column Radiator Feet Raw Metal (pack of 2 feet)



VALVE RECOMMENDATION

Our valve recommendation is a 1/2" Bentley Thermostatic Radiator Valve Lock-Shield pack in Black Nickel.

Code EV-B15BN

See our full valve section for more options - starting on page 32.



VALERIE

Vertical Flat Panel Radiators

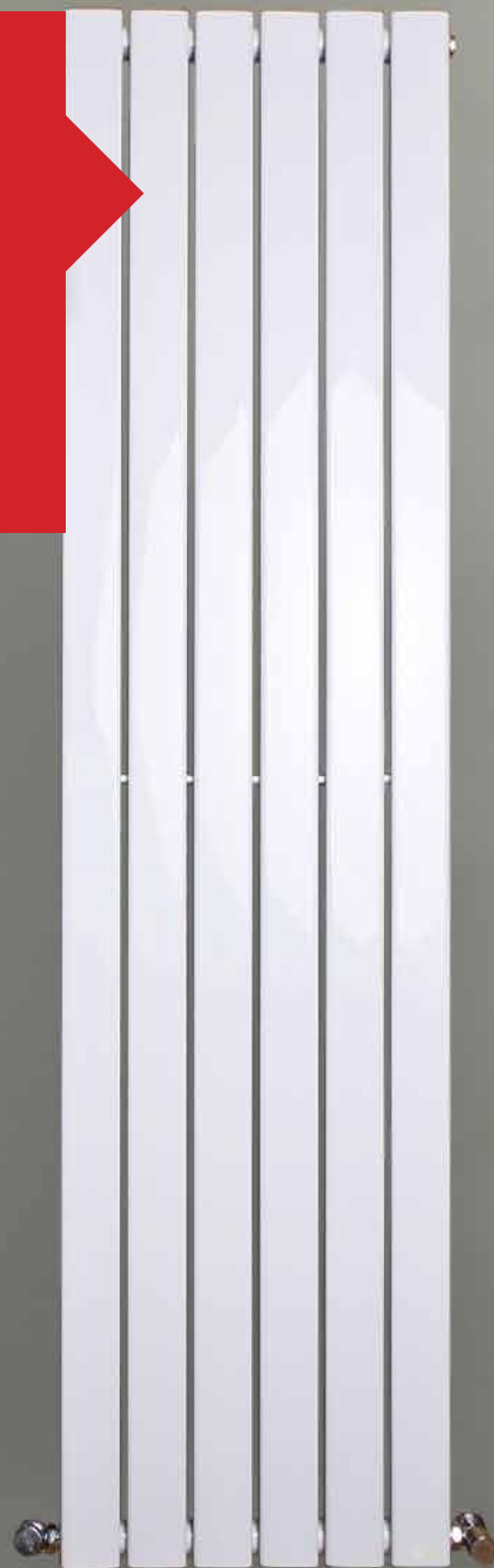

VALERIE – FLAT PANEL SINGLE

The vertical flat panel radiators are the ultimate space saver in any home. These radiators are strikingly stylish yet highly practical, blending into both period and modern interiors.

| | Colour | Height (mm) | Width (mm) | BTU | Watts | Pipe Centres | |
|---------|--------|-------------|------------|------|-------|--------------|---------|
| VFP418W | White | 1800 | 450 | 3253 | 953 | 540 | €378.23 |
| VFP518W | White | 1800 | 525 | 3795 | 1112 | 615 | €393.35 |
| VFP618W | White | 1800 | 600 | 4337 | 1271 | 690 | €423.61 |
| VFP420W | White | 2000 | 450 | 3590 | 1052 | 540 | €393.35 |
| VFP520W | White | 2000 | 525 | 4188 | 1227 | 615 | €438.74 |
| VFP620W | White | 2000 | 600 | 4786 | 1403 | 690 | €453.87 |

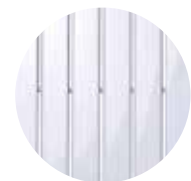

White

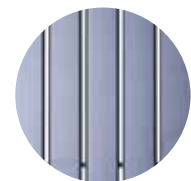

Anthracite

| | Colour | Height (mm) | Width (mm) | BTU | Watts | Pipe Centres | |
|---------|------------|-------------|------------|------|-------|--------------|---------|
| VFP418A | Anthracite | 1800 | 450 | 3253 | 953 | 540 | €469.00 |
| VFP518A | Anthracite | 1800 | 525 | 3795 | 1112 | 615 | €499.26 |
| VFP618A | Anthracite | 1800 | 600 | 4337 | 1271 | 690 | €544.64 |
| VFP420A | Anthracite | 2000 | 450 | 3590 | 1052 | 540 | €499.26 |
| VFP520A | Anthracite | 2000 | 525 | 4188 | 1227 | 615 | €544.64 |
| VFP620A | Anthracite | 2000 | 600 | 4786 | 1403 | 690 | €574.90 |

VALERIE – FLAT PANEL DOUBLE

| | Colour | Height (mm) | Width (mm) | BTU | Watts | Pipe Centres | |
|-----------|------------|-------------|------------|------|-------|--------------|---------|
| VFP418WDP | White | 1800 | 452 | 6304 | 1848 | 542 | €418.20 |
| VFP518WDP | White | 1800 | 525 | 7354 | 2155 | 615 | €479.70 |
| VFP418ADP | Anthracite | 1800 | 452 | 6304 | 1848 | 542 | €435.42 |
| VFP518ADP | Anthracite | 1800 | 525 | 7354 | 2155 | 615 | €500.61 |



VALVE RECOMMENDATION

Our valve recommendation is the 1/2" Minimalist Angled Radiator Valve in Silver Nickel.

Code HP15SN

See our full valve section for more options - starting on page 32.



HAYLEY

Horizontal Flat Panel Radiators



HAYLEY FLAT PANEL HORIZONTAL - SINGLE

The Hayley horizontal flat panel radiators are the perfect solution for those who are looking for a modern alternative to standard panel radiators. The Hayley radiators will suit any interior and are available in both single and double panel options.



White

| | Colour | Height (mm) | Width (mm) | BTU | Watts | Pipe Centres | |
|---------|--------|-------------|------------|------|-------|--------------|---------|
| FP11506 | White | 500 | 600 | 1631 | 478 | 690 | €213.13 |
| FP11508 | White | 500 | 800 | 2174 | 637 | 890 | €246.07 |
| FP11510 | White | 500 | 1000 | 2718 | 797 | 1090 | €278.68 |
| FP11512 | White | 500 | 1200 | 3261 | 956 | 1290 | €314.22 |
| FP11514 | White | 500 | 1400 | 3805 | 1115 | 1490 | €349.75 |
| FP11516 | White | 500 | 1600 | 4348 | 1274 | 1690 | €384.99 |
| FP11518 | White | 500 | 1800 | 4892 | 1434 | 1890 | €423.74 |
| FP11520 | White | 500 | 2000 | 5435 | 1593 | 2090 | €465.44 |
| FP11606 | White | 600 | 600 | 1834 | 537 | 690 | €235.00 |
| FP11608 | White | 600 | 800 | 2446 | 717 | 890 | €270.88 |
| FP11610 | White | 600 | 1000 | 3057 | 896 | 1090 | €306.50 |
| FP11612 | White | 600 | 1200 | 3669 | 1075 | 1290 | €346.66 |
| FP11614 | White | 600 | 1400 | 4280 | 1254 | 1490 | €386.76 |
| FP11616 | White | 600 | 1600 | 4891 | 1433 | 1690 | €426.69 |
| FP11618 | White | 600 | 1800 | 5503 | 1613 | 1890 | €475.37 |
| FP11620 | White | 600 | 2000 | 6114 | 1792 | 2090 | €515.35 |

VALVE RECOMMENDATION

Our valve recommendation is the 1/2" Valogin Thermostatic Radiator Valve & Lock-Shield Pack.

Code VGTRVP

See our full valve section for more options - starting on page 32.



HAYLEY FLAT PANEL HORIZONTAL - DOUBLE

| | Colour | Height (mm) | Width (mm) | BTU | Watts | Pipe Centres | |
|---------|--------|-------------|------------|-------|-------|--------------|---------|
| FP22406 | White | 400 | 600 | 2296 | 673 | 690 | €249.39 |
| FP22408 | White | 400 | 800 | 3062 | 897 | 890 | €289.90 |
| FP22410 | White | 400 | 1000 | 3827 | 1122 | 1090 | €331.71 |
| FP22412 | White | 400 | 1200 | 4593 | 1346 | 1290 | €379.43 |
| FP22414 | White | 400 | 1400 | 5358 | 1570 | 1490 | €427.02 |
| FP22416 | White | 400 | 1600 | 6124 | 1795 | 1690 | €475.94 |
| FP22418 | White | 400 | 1800 | 6889 | 2019 | 1890 | €532.73 |
| FP22420 | White | 400 | 2000 | 7654 | 2243 | 2090 | €581.74 |
| FP22506 | White | 500 | 600 | 2895 | 848 | 690 | €277.32 |
| FP22508 | White | 500 | 800 | 3860 | 1131 | 890 | €325.57 |
| FP22510 | White | 500 | 1000 | 4825 | 1414 | 1090 | €373.40 |
| FP22512 | White | 500 | 1200 | 5790 | 1697 | 1290 | €427.19 |
| FP22514 | White | 500 | 1400 | 6755 | 1980 | 1490 | €482.50 |
| FP22516 | White | 500 | 1600 | 7720 | 2263 | 1690 | €537.47 |
| FP22518 | White | 500 | 1800 | 8685 | 2545 | 1890 | €583.39 |
| FP22520 | White | 500 | 2000 | 9650 | 2828 | 2090 | €656.00 |
| FP22606 | White | 600 | 600 | 3500 | 1026 | 690 | €308.43 |
| FP22608 | White | 600 | 800 | 4666 | 1367 | 890 | €362.71 |
| FP22610 | White | 600 | 1000 | 5833 | 1709 | 1090 | €416.63 |
| FP22612 | White | 600 | 1200 | 6999 | 2051 | 1290 | €478.04 |
| FP22614 | White | 600 | 1400 | 8166 | 2393 | 1490 | €539.32 |
| FP22616 | White | 600 | 1600 | 9332 | 2735 | 1690 | €602.06 |
| FP22618 | White | 600 | 1800 | 10499 | 3077 | 1890 | €673.71 |
| FP22620 | White | 600 | 2000 | 11665 | 3419 | 2090 | €734.88 |



White

VALVE RECOMMENDATION

Our valve recommendation is the 1/2" Valogin Thermostatic Radiator Valve & Lock-Shield Pack.

Code VGTRVP

See our full valve section for more options - starting on page 32.



TOWEL WARMERS

Designer radiators to suit your home

TOWEL WARMERS



TWA €429.00
 Adare Traditional Towel Warmer
 Chrome & White
 H: 963mm W: 493mm
 Output: 2215 BTU/hr
 Pipe Centre: 458mm
 Watts: 649



TWE €675.00
 Avoca Traditional Towel Warmer
 Chrome & White
 H: 1130mm W: 553mm
 Output: 3275 BTU/hr
 Pipe Centre: 480mm
 Watts: 960



TWHTW €609.00
 Branwell Wall Hung Towel Warmer
 Chrome & White
 H: 1000mm W: 630mm
 Output: 3780 BTU/hr
 Valve Centers: 525mm
 Watts: 1108



TWW €491.00
 Cashel Traditional Towel Warmer
 Chrome & White
 H: 963mm W: 675mm
 Output: 3520 BTU/hr
 Pipe Centre: 953mm
 Watts: 1032



TWHAN2 €405.00
 Hannah Designer Towel Warmer
 Chrome
 H: 650 mm W: 1220mm
 Output: 1857 BTU/hr
 Pipe Centre: 1150mm
 Watts: 544



TWSKY €442.00
 Skyelor Designer Towel Warmer
 Chrome
 H: 1100mm W: 500mm
 Output: 1488 BTU/hr
 Pipe Centre: 450mm
 Watts: 436

STRAIGHT LADDER TOWEL WARMER

| | Colour | Height (mm) | Width (mm) | BTU | Watts | Pipe Centres | |
|--------|--------|-------------|------------|------|-------|--------------|---------|
| TW48S | Chrome | 800 | 400 | 870 | 255 | 350 | €109.00 |
| TW412S | Chrome | 1200 | 400 | 1262 | 370 | 350 | €160.00 |
| TW58S | Chrome | 800 | 500 | 1030 | 302 | 450 | €122.00 |
| TW512S | Chrome | 1200 | 500 | 1488 | 436 | 450 | €178.00 |
| TW68S | Chrome | 800 | 600 | 1194 | 350 | 550 | €133.00 |
| TW612S | Chrome | 1200 | 600 | 1726 | 506 | 550 | €191.00 |
| TW618S | Chrome | 1800 | 600 | 2620 | 768 | 550 | €309.00 |

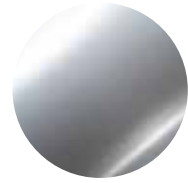

Chrome

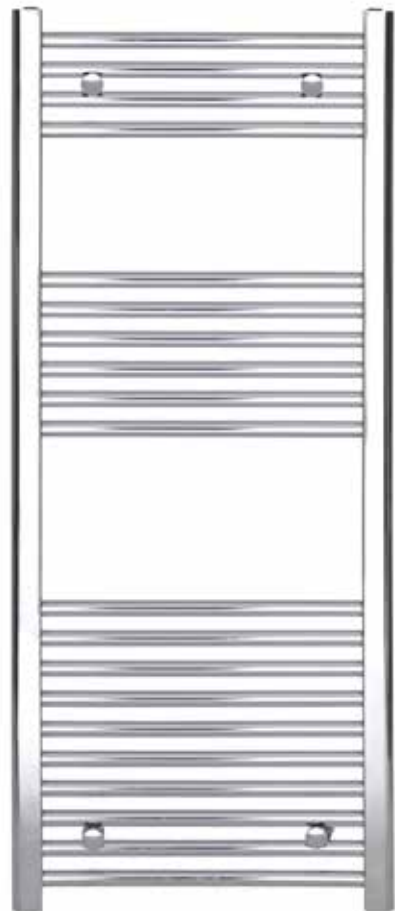

VALVE RECOMMENDATION

Our valve recommendation is a 1/2" Minimalist Angled Radiator Valve in Chrome.

Code RVCPM

See our full valve section for more options - starting on page 32.

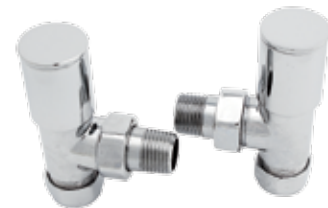



CURVED LADDER TOWEL WARMER

| | Colour | Height (mm) | Width (mm) | BTU | Watts | Pipe Centres | |
|--------|--------|-------------|------------|------|-------|--------------|---------|
| TW58C | Chrome | 800 | 500 | 1030 | 302 | 450 | €122.00 |
| TW512C | Chrome | 1200 | 500 | 1488 | 436 | 450 | €178.00 |
| TW68C | Chrome | 800 | 600 | 1194 | 350 | 550 | €133.00 |
| TW612C | Chrome | 1200 | 600 | 1726 | 506 | 550 | €191.00 |
| TW618C | Chrome | 1800 | 600 | 2620 | 768 | 550 | €309.00 |

| | | | | | | | |
|---------|------------|------|-----|------|-----|-----|---------|
| TW57C | Anthracite | 700 | 500 | 1143 | 335 | 450 | €183.00 |
| TW5115C | Anthracite | 1150 | 500 | 1855 | 544 | 450 | €245.00 |



Chrome

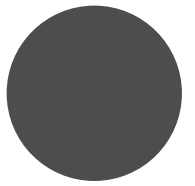

Anthracite

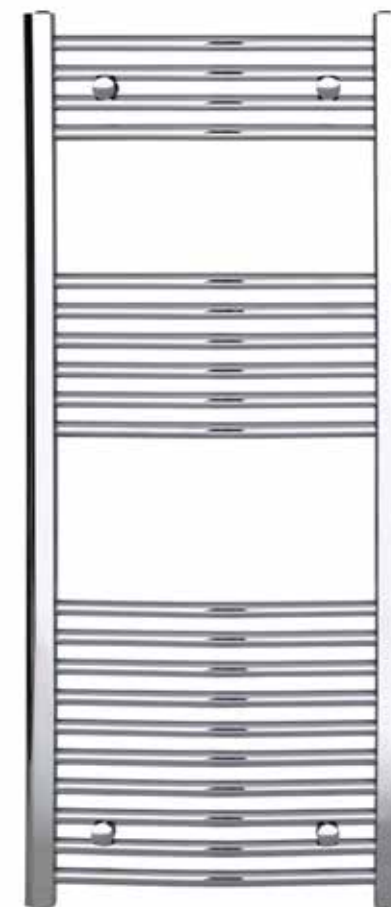

VALVE RECOMMENDATION

Our valve recommendation is a 1/2" Minimalist Angled Radiator Valve in Chrome.

Code RVCPM

See our full valve section for more options - starting on page 32.



MARIAH

Dual Column Mirror Radiator



MARIAH – DUAL COLUMN MIRROR

The Mariah Dual Column Mirror radiator ultimately combines functionality with style, blending seamlessly into any modern or period interior. This strikingly stylish radiator is sure to be the focal point of your room!

| | Colour | Height (mm) | Width (mm) | BTU | Watts | Pipe Centres | |
|----------|--------|-------------|------------|------|-------|--------------|---------|
| DCMR418W | White | 1800 | 450 | 3252 | 953 | 540 | €389.00 |

VALVE RECOMMENDATION

Our valve recommendation is a 1/2" Victorian Angled Radiator Valve in Chrome.

Code RVCPV

See our full valve section for more options - starting on page 32.



RUA

Designer Flat Panel



RUA – DESIGNER FLAT PANEL

The stunning designer flat panel radiators are pushing boundaries when it comes to ultra-modern design. The RUA radiator is the perfect heating solution in any room within the house including the bathroom! Pair this radiator with the RUA towel rail to ultimately transform your bathroom interior!

| | Colour | Height (mm) | Width (mm) | BTU | Watts | Pipe Centres | |
|---------|------------|-------------|------------|------|-------|--------------|---------|
| DFP418W | White | 1800 | 400 | 1979 | 580 | 490 | €356.70 |
| DFP518W | White | 1800 | 500 | 2474 | 725 | 590 | €430.50 |
| DFP618W | White | 1800 | 600 | 2969 | 870 | 690 | €504.30 |
| DFP418A | Anthracite | 1800 | 400 | 1979 | 580 | 490 | €369.00 |
| DFP518A | Anthracite | 1800 | 500 | 2474 | 725 | 590 | €442.80 |
| DFP618A | Anthracite | 1800 | 600 | 2969 | 870 | 690 | €516.60 |

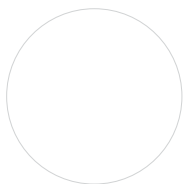

White

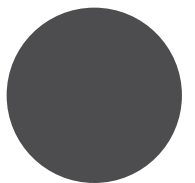

Anthracite

RUA TOWEL RAIL

| | Description | Colour | |
|-------|----------------------|--------|--------|
| HR500 | Rua 500mm Towel Rail | Chrome | €66.42 |
| HR600 | Rua 600mm Towel Rail | Chrome | €68.88 |
| HR700 | Rua 700mm Towel Rail | Chrome | €71.34 |



VALVE RECOMMENDATION

Our valve recommendation is the 1/2" Minimalist Corner Radiator Valves in Chrome.

Code C15C

See our full valve section for more options - starting on page 32.



SARA

Vertical Panel Radiators



SARA VERTICAL 3 PANEL ALUMINIUM RADIATOR

The Sara vertical aluminium flat panel delivers functionality, clean lines and a smooth finish making it a stylish radiator that doubles as a towel warmer when paired with the Sara Towel Rail.

| | Colour | Height (mm) | Width (mm) | BTU | Watts | Pipe Centres | |
|---------|------------|-------------|------------|------|-------|--------------|---------|
| VFP218W | White | 1800 | 280 | 2475 | 725 | 370 | €289.00 |
| VFP218A | Anthracite | 1800 | 280 | 2475 | 725 | 370 | €299.00 |

SARA VERTICAL 4 PANEL ALUMINIUM RADIATOR

| | Colour | Height (mm) | Width (mm) | BTU | Watts | Pipe Centres | |
|---------|------------|-------------|------------|------|-------|--------------|---------|
| VFP318W | White | 1800 | 375 | 3300 | 967 | 465 | €349.00 |
| VFP318A | Anthracite | 1800 | 375 | 3300 | 967 | 465 | €359.00 |

SARA TOWEL RAIL

| | Description | Colour | |
|-------|----------------------------------|--------|--------|
| HB415 | Sara 4 Panel Radiator Towel Rail | Chrome | €70.00 |
| HB320 | Sara 3 Panel Radiator Towel Rail | Chrome | €50.00 |



White



Anthracite



VALVE RECOMMENDATION

Our valve recommendation is the 1/2" Minimalist Corner Radiator Valves in Chrome.

Code C15C

See our full valve section for more options - starting on page 32.



IMAS

Compact Radiator Range



IMAS RADIATORS

Our compact radiators are designed to give maximum thermal heat outputs with a wide convector surface area.

400MM HIGH IMAS RADIATORS – SINGLE

| | Colour | Height (mm) | Width (mm) | BTU | Watts | Pipe Centres | |
|-------|--------|-------------|------------|------|-------|--------------|---------|
| 11406 | White | 400 | 600 | 1335 | 391 | 690 | €50.74 |
| 11408 | White | 400 | 800 | 1781 | 522 | 890 | €59.69 |
| 11409 | White | 400 | 900 | 2004 | 587 | 990 | €66.05 |
| 11410 | White | 400 | 1000 | 2227 | 653 | 1090 | €70.48 |
| 11411 | White | 400 | 1100 | 2450 | 718 | 1190 | €76.70 |
| 11412 | White | 400 | 1200 | 2673 | 783 | 1290 | €82.89 |
| 11414 | White | 400 | 1400 | 3118 | 914 | 1490 | €103.64 |
| 11416 | White | 400 | 1600 | 3561 | 1044 | 1690 | €114.38 |
| 11418 | White | 400 | 1800 | 4007 | 1174 | 1890 | €128.79 |
| 11420 | White | 400 | 2000 | 4454 | 1305 | 2090 | €153.43 |

500MM HIGH IMAS RADIATORS – SINGLE

| | Colour | Height (mm) | Width (mm) | BTU | Watts | Pipe Centres | |
|-------|--------|-------------|------------|------|-------|--------------|---------|
| 11504 | White | 500 | 400 | 1140 | 334 | 490 | €42.78 |
| 11505 | White | 500 | 500 | 1425 | 418 | 590 | €50.87 |
| 11506 | White | 500 | 600 | 1710 | 501 | 690 | €57.76 |
| 11507 | White | 500 | 700 | 1996 | 585 | 790 | €62.88 |
| 11508 | White | 500 | 800 | 2281 | 668 | 890 | €67.96 |
| 11509 | White | 500 | 900 | 2566 | 752 | 990 | €73.05 |
| 11510 | White | 500 | 1000 | 2851 | 836 | 1090 | €78.17 |
| 11511 | White | 500 | 1100 | 3136 | 919 | 1190 | €86.46 |
| 11512 | White | 500 | 1200 | 3421 | 1003 | 1290 | €95.12 |
| 11513 | White | 500 | 1300 | 3706 | 1086 | 1390 | €104.45 |
| 11514 | White | 500 | 1400 | 3991 | 1170 | 1490 | €113.27 |
| 11515 | White | 500 | 1500 | 4276 | 1253 | 1590 | €132.74 |
| 11516 | White | 500 | 1600 | 4561 | 1337 | 1690 | €124.98 |
| 11518 | White | 500 | 1800 | 5131 | 1504 | 1890 | €140.93 |
| 11520 | White | 500 | 2000 | 5702 | 1671 | 2090 | €156.42 |

600MM HIGH IMAS RADIATORS - SINGLE

| | Colour | Height (mm) | Width (mm) | BTU | Watts | Pipe Centres | |
|-------|--------|-------------|------------|------|-------|--------------|---------|
| 11605 | White | 600 | 500 | 1645 | 482 | 590 | €65.44 |
| 11606 | White | 600 | 600 | 1974 | 579 | 690 | €72.73 |
| 11607 | White | 600 | 700 | 2303 | 675 | 790 | €78.12 |
| 11608 | White | 600 | 800 | 2633 | 772 | 890 | €85.58 |
| 11609 | White | 600 | 900 | 2962 | 868 | 990 | €90.79 |
| 11610 | White | 600 | 1000 | 3291 | 964 | 1090 | €101.55 |
| 11611 | White | 600 | 1100 | 3620 | 1061 | 1190 | €103.44 |
| 11612 | White | 600 | 1200 | 3949 | 1157 | 1290 | €113.73 |
| 11614 | White | 600 | 1400 | 4607 | 1350 | 1490 | €146.84 |
| 11616 | White | 600 | 1600 | 5265 | 1543 | 1690 | €163.44 |
| 11618 | White | 600 | 1800 | 5923 | 1736 | 1890 | €177.74 |
| 11620 | White | 600 | 2000 | 6581 | 1929 | 2090 | €201.58 |

400MM HIGH IMAS RADIATORS - DOUBLE

| | Colour | Height (mm) | Width (mm) | BTU | Watts | Pipe Centres | |
|-------|--------|-------------|------------|------|-------|--------------|---------|
| 22406 | White | 400 | 600 | 2547 | 746 | 690 | €101.27 |
| 22408 | White | 400 | 800 | 3396 | 995 | 890 | €119.15 |
| 22409 | White | 400 | 900 | 3821 | 1120 | 990 | €131.43 |
| 22410 | White | 400 | 1000 | 4245 | 1244 | 1090 | €142.18 |
| 22411 | White | 400 | 1100 | 4670 | 1369 | 1190 | €152.82 |
| 22412 | White | 400 | 1200 | 5095 | 1493 | 1290 | €160.28 |
| 22414 | White | 400 | 1400 | 5944 | 1742 | 1490 | €202.20 |
| 22416 | White | 400 | 1600 | 6793 | 1991 | 1690 | €221.25 |
| 22418 | White | 400 | 1800 | 7642 | 2240 | 1890 | €268.52 |
| 22420 | White | 400 | 2000 | 8491 | 2488 | 2090 | €279.22 |

300MM HIGH IMAS RADIATORS - DOUBLE

| | Colour | Height (mm) | Width (mm) | BTU | Watts | Pipe Centres | |
|-------|--------|-------------|------------|------|-------|--------------|---------|
| 22306 | White | 300 | 600 | 1995 | 585 | 690 | €99.16 |
| 22308 | White | 300 | 800 | 2660 | 780 | 890 | €119.96 |
| 22310 | White | 300 | 1000 | 3325 | 974 | 1090 | €137.19 |
| 22312 | White | 300 | 1200 | 3990 | 1169 | 1290 | €164.03 |
| 22314 | White | 300 | 1400 | 4655 | 1364 | 1490 | €190.90 |
| 22316 | White | 300 | 1600 | 5320 | 1559 | 1690 | €220.16 |
| 22318 | White | 300 | 1800 | 5985 | 1754 | 1890 | €249.51 |
| 22320 | White | 300 | 2000 | 6650 | 1949 | 2090 | €278.88 |

500MM HIGH IMAS RADIATORS - DOUBLE

| | Colour | Height (mm) | Width (mm) | BTU | Watts | Pipe Centres | |
|-------|--------|-------------|------------|-------|-------|--------------|---------|
| 22504 | White | 500 | 400 | 2049 | 601 | 490 | €80.55 |
| 22505 | White | 500 | 500 | 2561 | 751 | 590 | €99.77 |
| 22506 | White | 500 | 600 | 3073 | 901 | 690 | €117.17 |
| 22507 | White | 500 | 700 | 3585 | 1051 | 790 | €132.32 |
| 22508 | White | 500 | 800 | 4097 | 1201 | 890 | €143.07 |
| 22509 | White | 500 | 900 | 4610 | 1351 | 990 | €153.79 |
| 22510 | White | 500 | 1000 | 5122 | 1501 | 1090 | €164.51 |
| 22511 | White | 500 | 1100 | 5634 | 1651 | 1190 | €186.57 |
| 22512 | White | 500 | 1200 | 6146 | 1801 | 1290 | €197.62 |
| 22513 | White | 500 | 1300 | 6658 | 1951 | 1390 | €221.12 |
| 22514 | White | 500 | 1400 | 7171 | 2102 | 1490 | €238.29 |
| 22515 | White | 500 | 1500 | 7683 | 2252 | 1590 | €250.50 |
| 22516 | White | 500 | 1600 | 8195 | 2402 | 1690 | €262.13 |
| 22518 | White | 500 | 1800 | 9219 | 2702 | 1890 | €297.76 |
| 22520 | White | 500 | 2000 | 10244 | 3002 | 2090 | €339.68 |

600MM HIGH IMAS RADIATORS - DOUBLE

| | Colour | Height (mm) | Width (mm) | BTU | Watts | Pipe Centres | |
|-------|--------|-------------|------------|-------|-------|--------------|---------|
| 22605 | White | 600 | 500 | 3045 | 892 | 590 | €120.86 |
| 22606 | White | 600 | 600 | 3654 | 1071 | 690 | €136.94 |
| 22607 | White | 600 | 700 | 4263 | 1249 | 790 | €144.27 |
| 22608 | White | 600 | 800 | 4872 | 1428 | 890 | €161.12 |
| 22609 | White | 600 | 900 | 5481 | 1606 | 990 | €167.65 |
| 22610 | White | 600 | 1000 | 6090 | 1785 | 1090 | €185.29 |
| 22611 | White | 600 | 1100 | 6699 | 1963 | 1190 | €195.78 |
| 22612 | White | 600 | 1200 | 7308 | 2142 | 1290 | €219.87 |
| 22614 | White | 600 | 1400 | 8526 | 2499 | 1490 | €293.67 |
| 22616 | White | 600 | 1600 | 9744 | 2856 | 1690 | €311.23 |
| 22618 | White | 600 | 1800 | 10962 | 3213 | 1890 | €349.34 |
| 22620 | White | 600 | 2000 | 12181 | 3570 | 2090 | €388.16 |

VALVE RECOMMENDATION

Our valve recommendation for the Imas Range is the 1/2" Pegler Terrier Thermostatic Radiator Valve & Lock-Shield Pack.

Code PTRVPACK

See our full valve section for more options - starting on page 32.



VALVES

A carefully selected range of valves to suit your style



VGTRVP €15.99
1/2" Valogin Thermostatic Radiator Valve & Lock-Shield Pack



BTRVP €19.93
1/2" Bi-World Thermostatic Radiator Valve & Lock-Shield Pack



BTRVPG €34.44
1/2" Bi-World GB Female Thermostatic Radiator Valve & Lock-Shield Pack



PTRVPA €36.06
1/2" Pegler Terrier Thermostatic Radiator Valve & Lock-Shield Pack



RVTS €50.60
1/2" Pegler Terrier Straight Thermostatic Radiator Valve & Lock-Shield Pack



PTRVPC €49.29
1/2" Pegler Angled Thermostatic Radiator Valve & Lock-Shield Pack Chrome



RVTS €50.16
1/2" Pegler Straight Thermostatic Radiator Valve & Lock Shield Pack Chrome



RVCP €17.54
1/2" Contract Angled Chrome Radiator Valves (Pair)



RVSCP €18.99
1/2" Contract Straight Chrome Radiator Valves (Pair)



RVCPM €37.20
1/2" Minimalist Angled Radiator Valves Chrome (Pair)



RVSCPM €37.20
1/2" Minimalist Straight Chrome Radiator Valves (Pair)



BMRVA €39.36
1/2" Modern Angled Radiator Valves Chrome (Pair)



RVCPV €47.82
1/2" Victorian Angled Radiator Valves Chrome (Pair)



RVSCP €47.82
1/2" Victorian Straight Radiator Valves Chrome (Pair)



RVCPH €37.20
1/2" Helix Angled Chrome Radiator Valves (Pair)



RVSCPH €37.20
1/2" Helix Straight Chrome Radiator Valves (Pair)



HP15AB €54.12
1/2" Minimalist Angled Radiator Valves Antique Brass



HP15AC €54.12
1/2" Minimalist Angled Radiator Valves Antique Copper



HP15BN €54.12
1/2" Minimalist Angled Radiator Valves Black Nickel



HP15SN €54.12
1/2" Minimalist Angled Radiator Valves Silver Nickel



EV-B15C €152.40
1/2" Bentley Thermostatic Radiator Valve & Lock-Shield Pack Chrome



EV-B15SN €152.40
1/2" Bentley Thermostatic Radiator Valve Lock-Shield Pack Silver Nickel



EV-BG15AB €178.23
1/2" Bentley Gothic Thermostatic Radiator Valve & Lock-Shield Pack Antique Brass



EV-BG15AC €178.23
1/2" Bentley Gothic Thermostatic Radiator Valve & Lock-Shield Pack Antique Copper



HP15SAB €54.12
1/2" Minimalist Straight Radiator Valves Antique Brass



HP15SAC €54.12
1/2" Minimalist Straight Radiator Valves Antique Copper



HP15SBN €54.12
1/2" Minimalist Straight Radiator Valves Black Nickel



HP15SSN €54.12
1/2" Minimalist Straight Radiator Valves Silver Nickel



EV-BG15SN €178.23
1/2" Bentley Gothic Thermostatic Radiator Valve & Lock-Shield Pack Silver Nickel



BTRVPAS €27.06
Bi-World Straight Thermostatic Radiator Valve & Lock-Shield Pack



BTRVPACS €34.44
Bi-World Straight Thermostatic Radiator Valve & Lock-Shield Pack Chrome



BTRVPAC €34.44
Bi-World Angled Thermostatic Radiator Valve & Lock-Shield Pack Chrome



C15AB €54.12
1/2" Minimalist Corner Radiator Valves Antique Brass



C15AC €54.12
1/2" Minimalist Corner Radiator Valves Antique Copper



C15BN €54.12
1/2" Minimalist Corner Radiator Valves Black Nickel



C15SN €54.12
1/2" Minimalist Corner Radiator Valves Silver Nickel



TC16AB €44.28
16mm x 300mm Tails & Decorative Covers Antique Brass



TC16AC €44.28
16mm x 300mm Tails & Decorative Covers Antique Copper



TC16BN €44.28
16mm x 300mm Tails & Decorative Covers Black Nickel



TC16SN €44.28
16mm x 300mm Tails & Decorative Covers Silver Nickel



C15C €39.36
1/2" Minimalist Corner Radiator Valves Chrome



EV-B15AB €152.40
1/2" Bentley Thermostatic Radiator Valve & Lock-Shield Pack Antique Brass



EV-B15AC €152.40
1/2" Bentley Thermostatic Radiator Valve & Lock-Shield Pack Antique Copper



EV-B15BN €152.40
1/2" Bentley Thermostatic Radiator Valve & Lock-Shield Pack Black Nickel



TC16C €44.28
16mm x 300mm Tails & Decorative Covers Chrome

TECHNICAL

Specifications

REVIVE

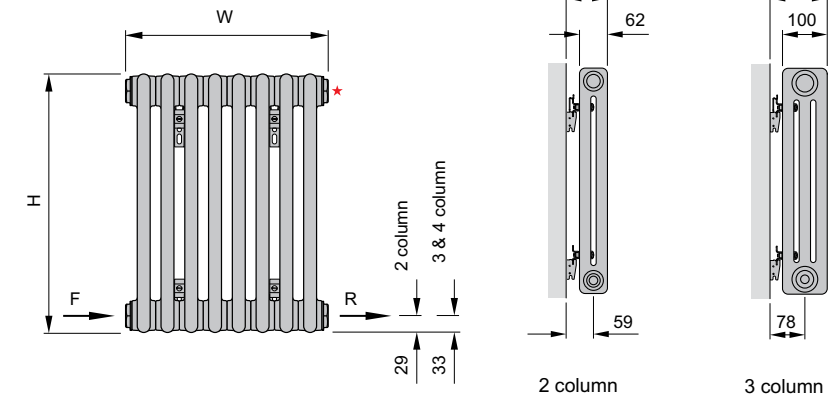

| | Height (mm) | Width (mm) | BTU | Watts | Pipe Centres |
|-------------|-------------|------------|------|-------|--------------|
| U2150-8 | 1500 | 398 | 2839 | 832 | 488 |
| U2180-8 | 1800 | 398 | 3385 | 992 | 488 |
| U2180-10 | 1800 | 490 | 4231 | 1240 | 580 |
| U2200-8 | 2000 | 398 | 3767 | 1104 | 488 |
| U2200-10 | 2000 | 490 | 4709 | 1380 | 580 |
| U2180-10-RM | 1800 | 490 | 4231 | 1240 | 580 |
| U2200-10-RM | 2000 | 490 | 4709 | 1380 | 580 |
| U2180-10-BK | 1800 | 490 | 4231 | 1240 | 580 |
| U2200-10-BK | 2000 | 490 | 4709 | 1380 | 580 |
| U3200-10 | 2000 | 490 | 6244 | 1830 | 580 |
| U3200-10-RM | 2000 | 490 | 6244 | 1830 | 580 |
| U3180-10 | 1800 | 490 | 5664 | 1660 | 580 |
| U3180-10-RM | 1800 | 490 | 5664 | 1660 | 580 |
| U3060-13 | 600 | 628 | 2701 | 792 | 718 |

| | Height (mm) | Width (mm) | BTU | Watts | Pipe Centres |
|-------------|-------------|------------|------|-------|--------------|
| U3060-19 | 600 | 904 | 3948 | 1157 | 994 |
| U3060-25 | 600 | 1180 | 5195 | 1523 | 1270 |
| U3060-32 | 600 | 1502 | 6649 | 1949 | 1592 |
| U3060-36 | 600 | 1686 | 7480 | 2192 | 1776 |
| U3060-13-RM | 600 | 628 | 2701 | 792 | 718 |
| U3060-19-RM | 600 | 904 | 3948 | 1157 | 994 |
| U3060-25-RM | 600 | 1180 | 5195 | 1523 | 1270 |
| U3060-32-RM | 600 | 1502 | 6649 | 1949 | 1592 |
| U3060-36-RM | 600 | 1686 | 7480 | 2192 | 1776 |
| U3060-13-BK | 600 | 628 | 2701 | 792 | 718 |
| U3060-19-BK | 600 | 904 | 3948 | 1157 | 994 |
| U3060-25-BK | 600 | 1180 | 5195 | 1523 | 1270 |
| U3060-32-BK | 600 | 1502 | 6649 | 1949 | 1592 |
| U3060-36-BK | 600 | 1686 | 7480 | 2192 | 1776 |

VALERIE - SINGLE

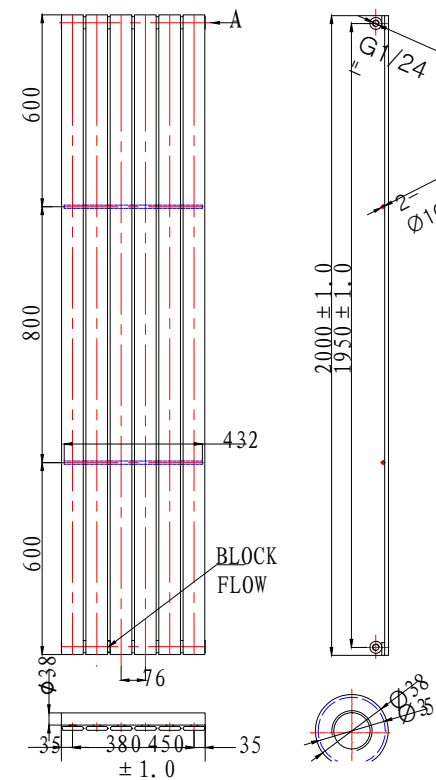

| | Height (mm) | Width (mm) | BTU | Watts | Pipe Centres |
|---------|-------------|------------|------|-------|--------------|
| VFP418W | 1800 | 450 | 3253 | 953 | 540 |
| VFP518W | 1800 | 525 | 3795 | 1112 | 615 |
| VFP618W | 1800 | 600 | 4337 | 1271 | 690 |
| VFP420W | 2000 | 450 | 3590 | 1052 | 540 |
| VFP520W | 2000 | 525 | 4188 | 1227 | 615 |
| VFP620W | 2000 | 600 | 4786 | 1403 | 690 |
| VFP418A | 1800 | 450 | 3253 | 953 | 540 |
| VFP518A | 1800 | 525 | 3795 | 1112 | 615 |
| VFP618A | 1800 | 600 | 4337 | 1271 | 690 |
| VFP420A | 2000 | 450 | 3590 | 1052 | 540 |
| VFP520A | 2000 | 525 | 4188 | 1227 | 615 |
| VFP620A | 2000 | 600 | 4786 | 1403 | 690 |

VALERIE - DOUBLE

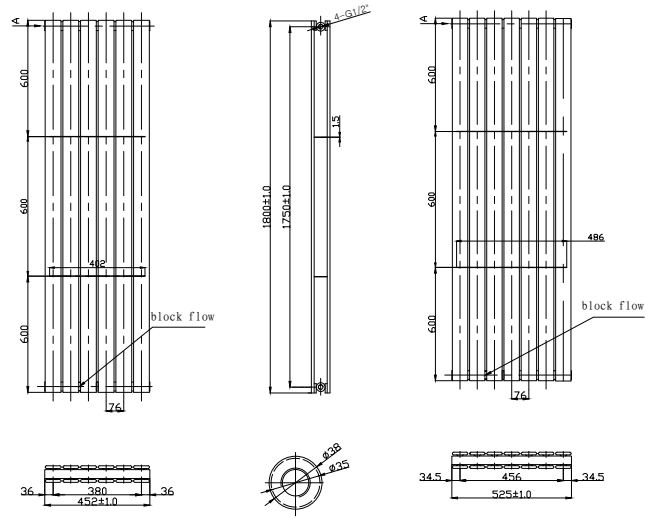

| | Height (mm) | Width (mm) | BTU | Watts | Pipe Centres |
|-----------|-------------|------------|------|-------|--------------|
| VFP418WDP | 1800 | 452 | 6304 | 1848 | 542 |
| VFP518WDP | 1800 | 525 | 7354 | 2155 | 615 |
| VFP418ADP | 1800 | 452 | 6304 | 1848 | 542 |
| VFP518ADP | 1800 | 535 | 7354 | 2155 | 615 |

HAYLEY

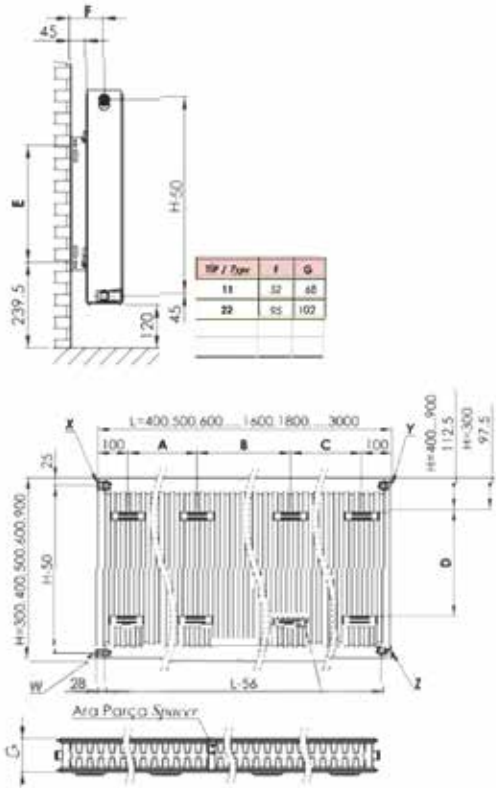

| | Height (mm) | Width (mm) | BTU | Watts | Pipe Centres |
|---------|-------------|------------|-------|-------|--------------|
| FP11608 | 600 | 800 | 2446 | 717 | 890 |
| FP11610 | 600 | 1000 | 3057 | 896 | 1090 |
| FP11612 | 600 | 1200 | 3669 | 1075 | 1290 |
| FP11614 | 600 | 1400 | 4280 | 1254 | 1490 |
| FP11616 | 600 | 1600 | 4891 | 1433 | 1690 |
| FP11618 | 600 | 1800 | 5503 | 1613 | 1890 |
| FP11620 | 600 | 2000 | 6114 | 1792 | 2090 |
| FP22406 | 400 | 600 | 2296 | 673 | 690 |
| FP22408 | 400 | 800 | 3062 | 897 | 890 |
| FP22410 | 400 | 1000 | 3827 | 1122 | 1090 |
| FP22412 | 400 | 1200 | 4593 | 1346 | 1290 |
| FP22414 | 400 | 1400 | 5358 | 1570 | 1490 |
| FP22416 | 400 | 1600 | 6124 | 1795 | 1690 |
| FP22418 | 400 | 1800 | 6889 | 2019 | 1890 |
| FP22420 | 400 | 2000 | 7654 | 2243 | 2090 |
| FP22506 | 500 | 600 | 2895 | 848 | 690 |
| FP22508 | 500 | 800 | 3860 | 1131 | 890 |
| FP22510 | 500 | 1000 | 4825 | 1414 | 1090 |
| FP22512 | 500 | 1200 | 5790 | 1697 | 1290 |
| FP22514 | 500 | 1400 | 6755 | 1980 | 1490 |
| FP22516 | 500 | 1600 | 7720 | 2263 | 1690 |
| FP22518 | 500 | 1800 | 8685 | 2545 | 1890 |
| FP22520 | 500 | 2000 | 9650 | 2828 | 2090 |
| FP22606 | 600 | 600 | 3500 | 1026 | 690 |
| FP22608 | 600 | 800 | 4666 | 1367 | 890 |
| FP22610 | 600 | 1000 | 5833 | 1709 | 1090 |
| FP22612 | 600 | 1200 | 6999 | 2051 | 1290 |
| FP22614 | 600 | 1400 | 8166 | 2393 | 1490 |
| FP22616 | 600 | 1600 | 9332 | 2735 | 1690 |
| FP22618 | 600 | 1800 | 10499 | 3077 | 1890 |
| FP22620 | 600 | 2000 | 11665 | 3419 | 2090 |

| | Height (mm) | Width (mm) | BTU | Watts | Pipe Centres |
|---------|-------------|------------|------|-------|--------------|
| FP11506 | 500 | 600 | 1631 | 478 | 690 |
| FP11508 | 500 | 800 | 2174 | 637 | 890 |
| FP11510 | 500 | 1000 | 2718 | 797 | 1090 |
| FP11512 | 500 | 1200 | 3261 | 956 | 1290 |
| FP11514 | 500 | 1400 | 3805 | 1115 | 1490 |
| FP11516 | 500 | 1600 | 4348 | 1274 | 1690 |
| FP11518 | 500 | 1800 | 4892 | 1434 | 1890 |
| FP11520 | 500 | 2000 | 5435 | 1593 | 2090 |
| FP11606 | 600 | 600 | 1834 | 537 | 690 |

TOWEL WARMERS

TWA

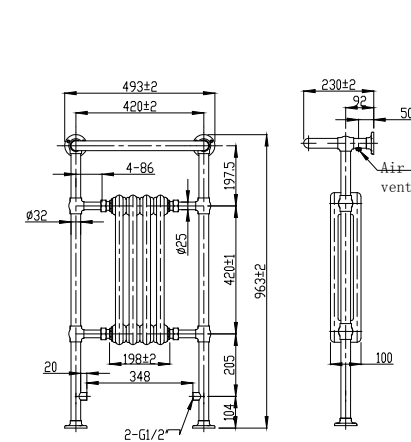

TWE

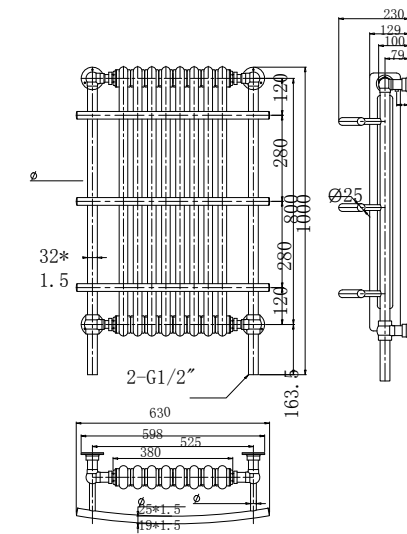

TWHTW

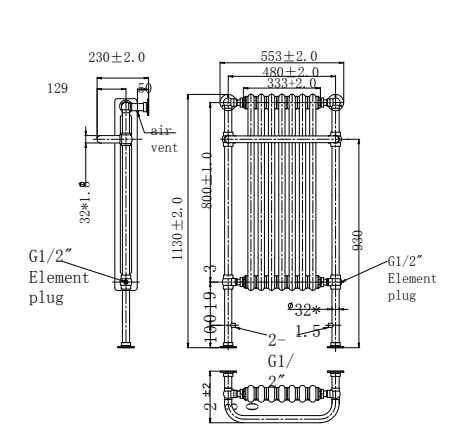

TWV

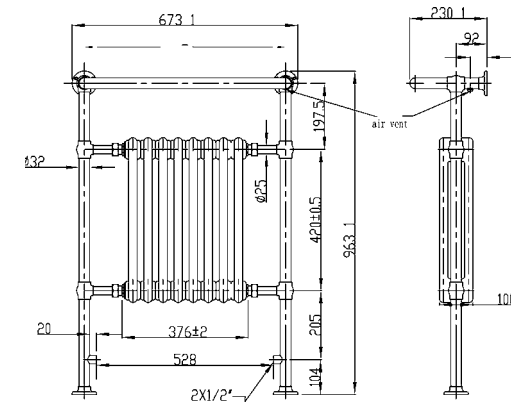

TWHAN2

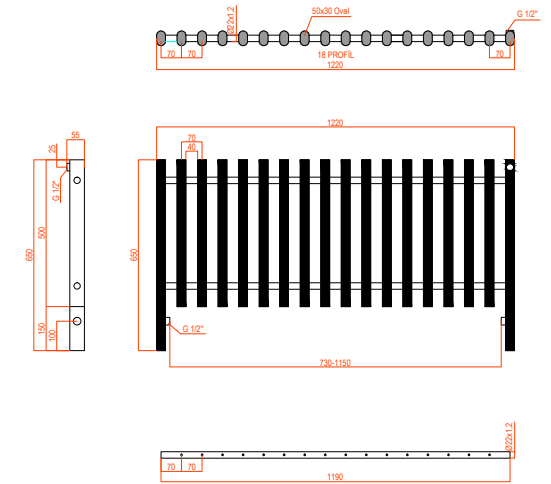

TWSKY

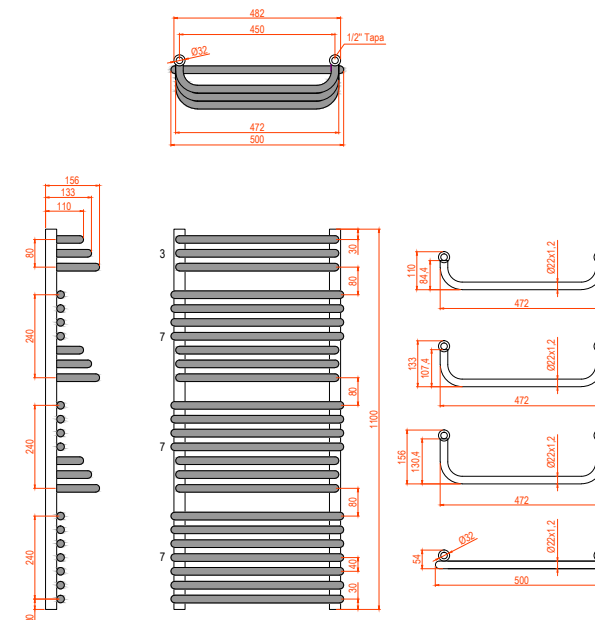

| | Height (mm) | Width (mm) | BTU | Watts | Pipe Centres |
|--------|-------------|------------|------|-------|--------------|
| TWA | 963 | 493 | 2215 | 649 | 458 |
| TWE | 1130 | 553 | 3275 | 960 | 480 |
| TWHTW | 1000 | 630 | 3780 | 1108 | 525 |
| TWV | 963 | 675 | 3520 | 1032 | 953 |
| TWHAN2 | 1200 | 650 | 1857 | 544 | 1150 |
| TWSKY | 1100 | 500 | 1488 | 436 | 450 |

TOWEL WARMERS

TW48S

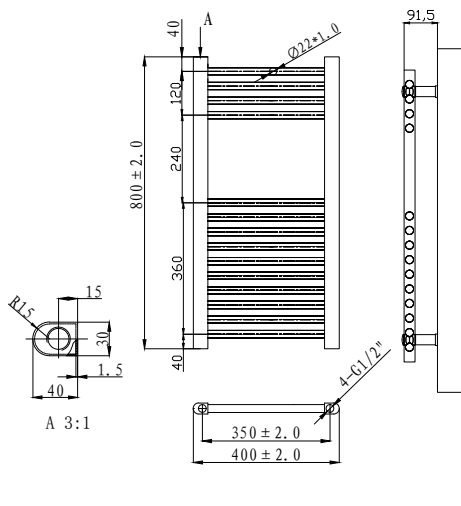

TW412S

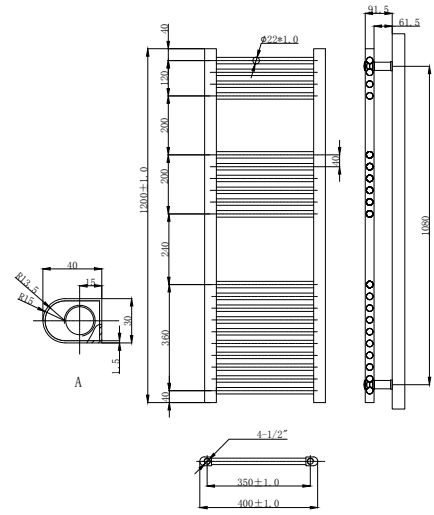

TW58S

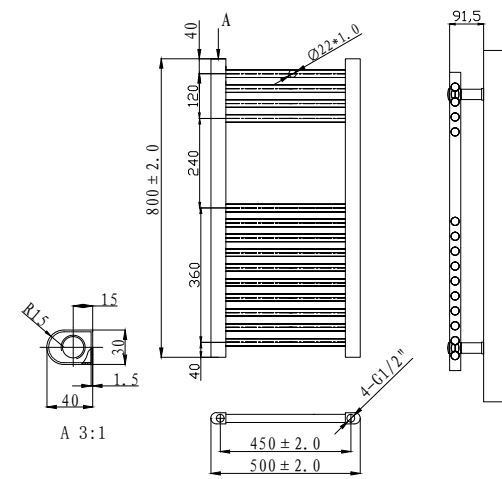

TOWEL WARMERS

TW512C

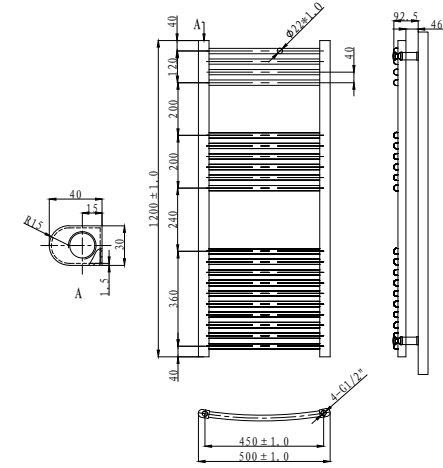

TW68C

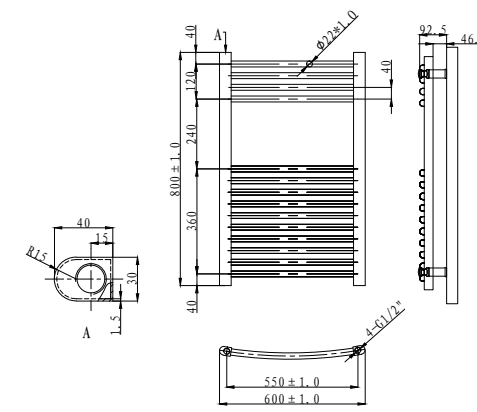

TW612C

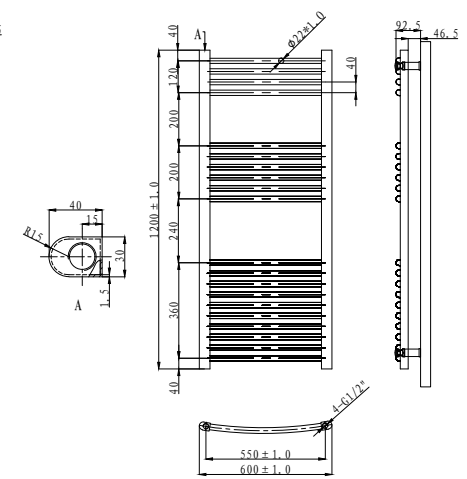

TW512S

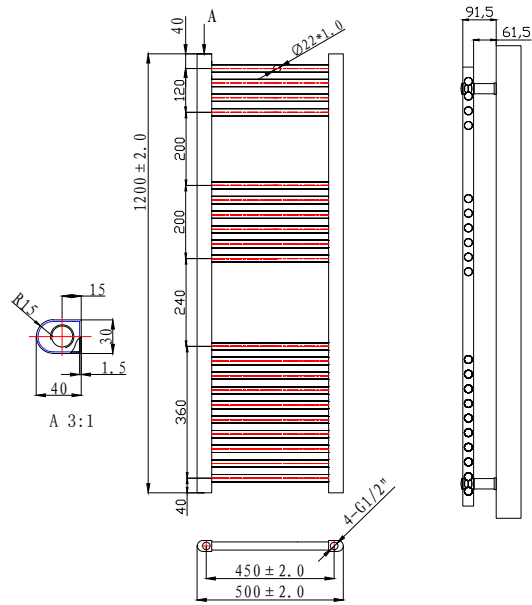

TW68S

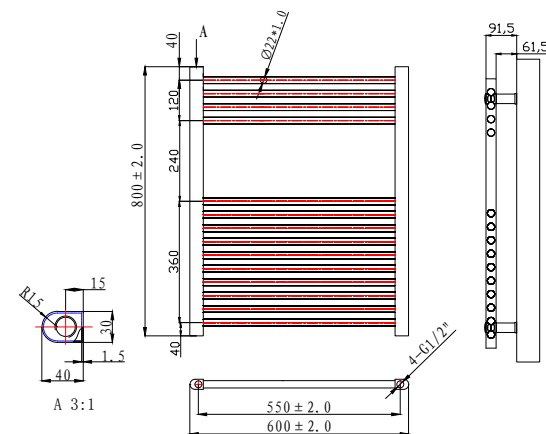

TW618C

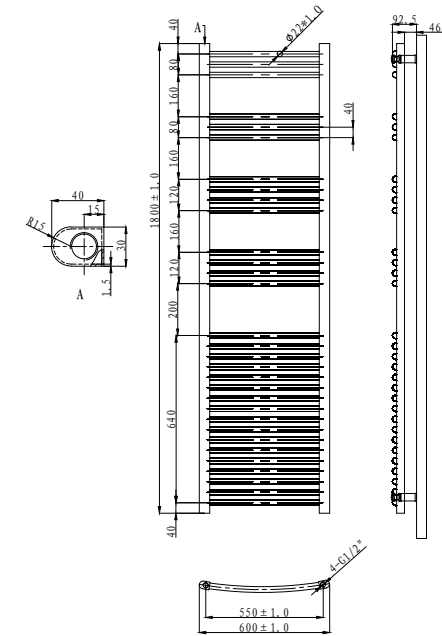

TW57C

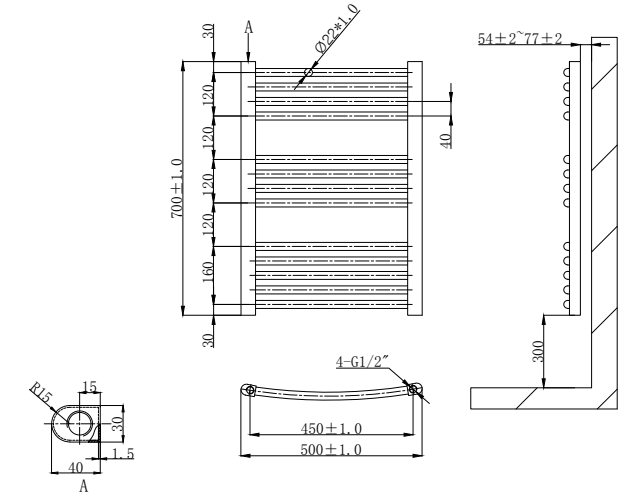

TW612S

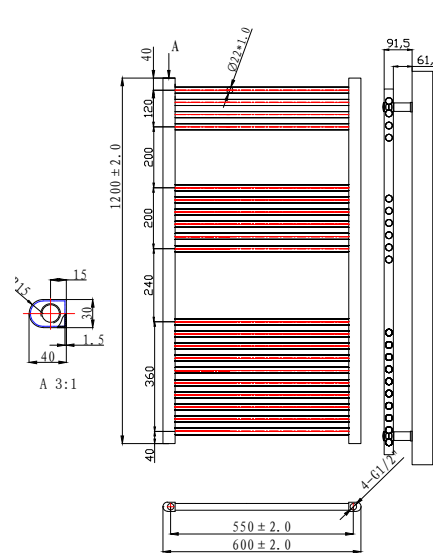

TW618S

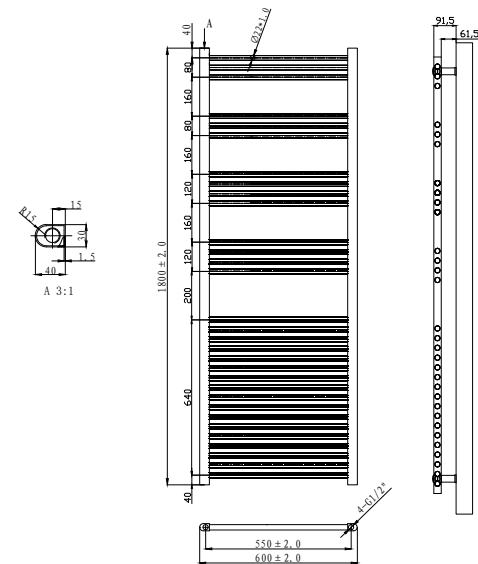

TW58C

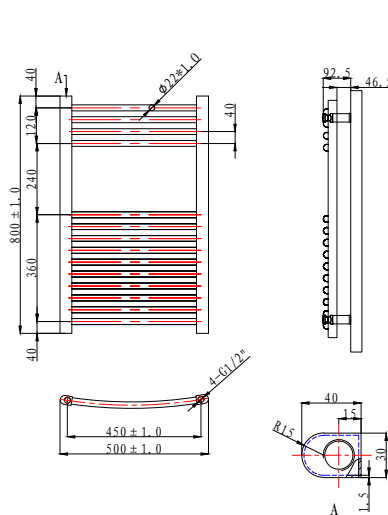

TW5155C

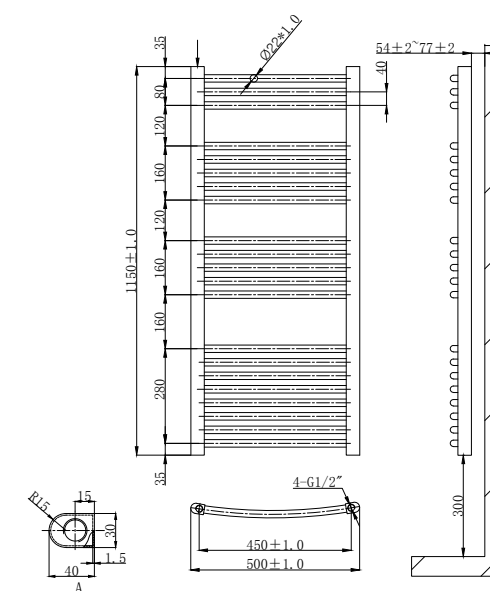

| | Height (mm) | Width (mm) | BTU | Watts | Pipe Centres |
|---------|-------------|------------|------|-------|--------------|
| TW48S | 800 | 400 | 870 | 255 | 350 |
| TW412S | 1200 | 400 | 1262 | 370 | 350 |
| TW58S | 800 | 500 | 1030 | 302 | 450 |
| TW512S | 1200 | 500 | 1488 | 436 | 450 |
| TW68S | 800 | 600 | 1194 | 350 | 550 |
| TW612S | 1200 | 600 | 1726 | 506 | 550 |
| TW618S | 1800 | 600 | 2620 | 768 | 550 |
| TW58C | 800 | 500 | 1030 | 302 | 450 |
| TW512C | 1200 | 500 | 1488 | 436 | 450 |
| TW68C | 800 | 500 | 1194 | 350 | 550 |
| TW612C | 1200 | 600 | 1726 | 506 | 550 |
| TW618C | 1800 | 600 | 2620 | 768 | 550 |
| TW57C | 700 | 500 | 1143 | 335 | 450 |
| TW5115C | 1150 | 500 | 1855 | 544 | 450 |

MARIAH

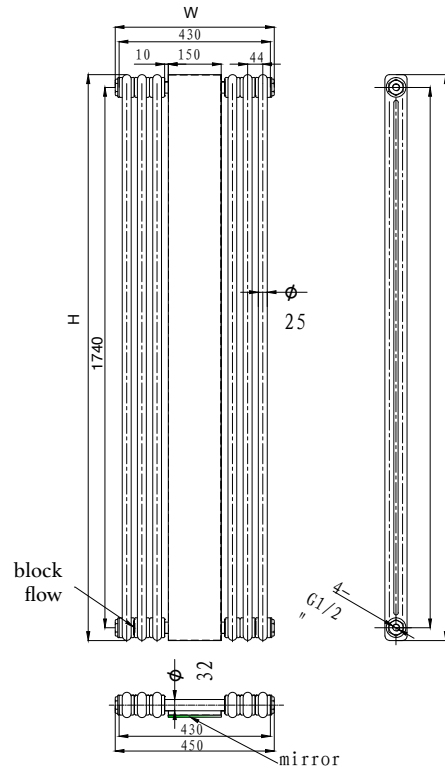

SARA

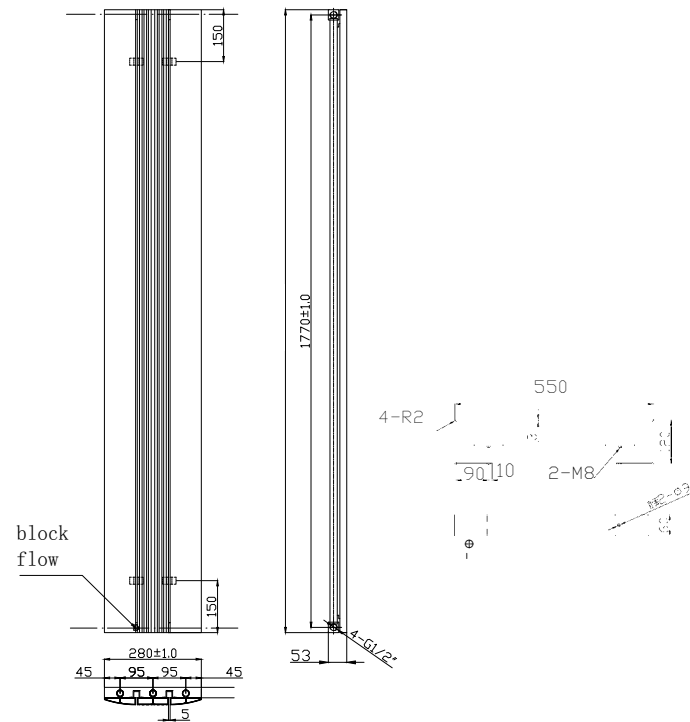

| | Height (mm) | Width (mm) | BTU | Watts | Pipe Centres |
|----------|-------------|------------|------|-------|--------------|
| DCMR418W | 1800 | 450 | 3252 | 953 | 540 |

| | Height (mm) | Width (mm) | BTU | Watts | Pipe Centres |
|---------|-------------|------------|------|-------|--------------|
| VFP218W | 1800 | 280 | 2475 | 725 | 370 |
| VFP218A | 1800 | 280 | 2475 | 725 | 370 |
| VFP318W | 1800 | 375 | 3300 | 967 | 465 |
| VFP318A | 1800 | 375 | 3300 | 967 | 465 |

RUA

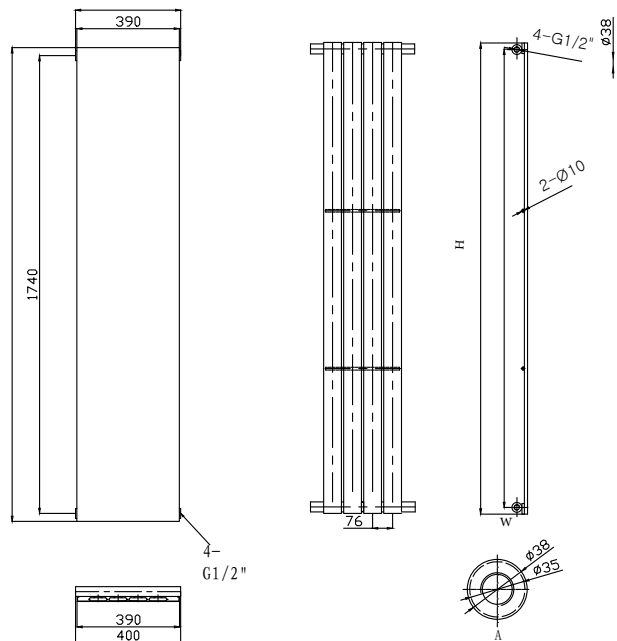

| | Тип / Type 21-22-33 | | | Тип / Type 11 | | | H | D | E |
|------------|---------------------|-----|------|---------------|--------|--------|-----|-----|-----|
| | A | B | C | A | B | C | | | |
| 400...1600 | - | - | - | - | - | - | 300 | 83 | 62 |
| 1800 | 800 | 0 | 800 | 766.67 | 0 | 800 | 400 | 150 | 129 |
| 2000 | 900 | 0 | 900 | 866.67 | 0 | 900 | 500 | 250 | 229 |
| 2200 | 1000 | 0 | 1000 | 966.67 | 0 | 1000 | 600 | 350 | 329 |
| 2400 | 1100 | 0 | 1100 | 1066.67 | 0 | 1100 | 700 | 650 | 629 |
| 2600 | 800 | 800 | 800 | 800 | 766.67 | 800 | | | |
| 2800 | 866 | 866 | 866 | 866.67 | 833.33 | 866.67 | | | |
| 3000 | 933 | 933 | 933 | 933.33 | 900 | 933.33 | | | |

| | Height (mm) | Width (mm) | BTU | Watts | Pipe Centres |
|---------|-------------|------------|------|-------|--------------|
| DFP418W | 1800 | 400 | 1979 | 580 | 490 |
| DFP518W | 1800 | 500 | 2474 | 725 | 590 |
| DFP618W | 1800 | 600 | 2969 | 870 | 690 |
| DFP418A | 1800 | 400 | 1979 | 580 | 490 |
| DFP518A | 1800 | 500 | 2474 | 725 | 590 |
| DFP618A | 1800 | 600 | 2969 | 870 | 690 |

IMAS

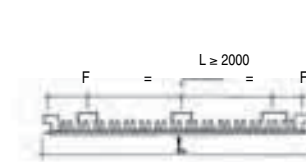

| | H (mm) | I (mm) | A (mm) | B (mm) | C (mm) | D (mm) | E (mm) | F (mm) |
|-----|--------|--------|--------|--------|--------|--------|--------|--------|
| 300 | 250 | 85 | 110 | 110 | 55 | 80 | 135 | |
| 400 | 350 | 85 | 110 | 150 | 115 | 140 | 135 | |
| 500 | 450 | 85 | 110 | 250 | 115 | 140 | 135 | |
| 600 | 550 | 85 | 110 | 350 | 115 | 140 | 135 | |
| 800 | 750 | 85 | 110 | 550 | 115 | 140 | 135 | |
| 900 | 850 | 85 | 110 | 650 | 115 | 140 | 135 | |

Standard brackets included in the packing

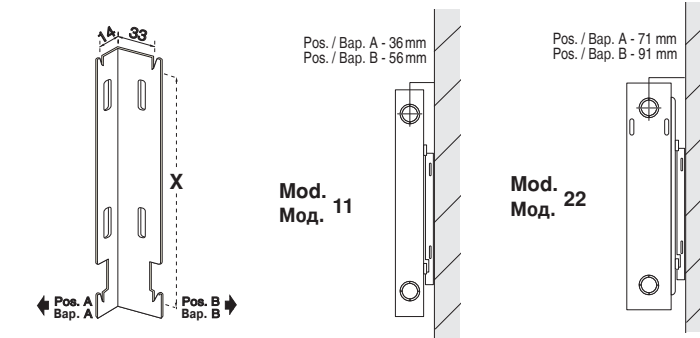

22-DK

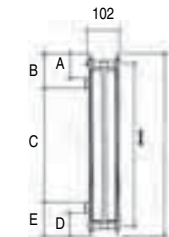
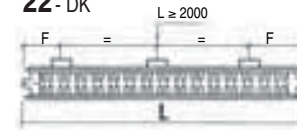

| | H (mm) | I (mm) | A (mm) | B (mm) | C (mm) | D (mm) | E (mm) | F (mm) |
|-----|--------|--------|--------|--------|--------|--------|--------|--------|
| 300 | 250 | 85 | 110 | 110 | 55 | 80 | 100 | |
| 400 | 350 | 85 | 110 | 150 | 115 | 140 | 100 | |
| 500 | 450 | 85 | 110 | 250 | 115 | 140 | 100 | |
| 600 | 550 | 85 | 110 | 350 | 115 | 140 | 100 | |
| 800 | 750 | 85 | 110 | 550 | 115 | 140 | 100 | |
| 900 | 850 | 85 | 110 | 650 | 115 | 140 | 100 | |

| L | n° handles n° держателя Št. nosilcev |
|-------------|--|
| 400 ÷ 1800 | 4 |
| 2000 ÷ 3000 | 6 |

ANCHORING SYSTEMS

Watt Heating output EN 442 Δt = 50 K

Inlet temp. 75 °C
Outlet temp. 65 °C
Room temp. 20 °C

| MOD. Мод. | H | L | | | | | | | | | | | | | | | | |
|------------------|-----|-----|-----|------|------|------|------|------|------|------|------|------|------|--|--|--|--|--|
| | | 400 | 500 | 600 | 700 | 800 | 900 | 1000 | 1200 | 1400 | 1600 | 1800 | 2000 | | | | | |
| 11 ASSOT23-03 | 400 | 281 | 352 | 422 | 492 | 562 | 633 | 703 | 844 | 984 | 1125 | 1265 | 1406 | | | | | |
| | 500 | 334 | 418 | 502 | 585 | 669 | 752 | 836 | 1003 | 1170 | 1338 | 1505 | 1672 | | | | | |
| | 600 | 386 | 483 | 580 | 676 | 773 | 869 | 966 | 1159 | 1352 | 1546 | 1739 | 1932 | | | | | |
| 22 ASSOT23-05 | 300 | 390 | 488 | 585 | 683 | 780 | 878 | 975 | 1170 | 1365 | 1560 | 1755 | 1950 | | | | | |
| | 400 | 498 | 623 | 747 | 872 | 996 | 1121 | 1245 | 1494 | 1743 | 1992 | 2241 | 2490 | | | | | |
| | 500 | 601 | 751 | 901 | 1051 | 1202 | 1352 | 1502 | 1802 | 2103 | 2403 | 2704 | 3004 | | | | | |
| | 600 | 722 | 903 | 1084 | 1264 | 1445 | 1625 | 1806 | 2167 | 2528 | 2889 | 3251 | 3612 | | | | | |

H. 900 available end of year 2010

11

Watt Heating output
 Inlet temp. **90 °C**
 Outlet temp. **70 °C**

| Room Temp. Темп. среды Temp. zraka (°C) | Height Высота Višina (mm) | Length - Длина - Dolžina (mm) | | | | | | | | | | | |
|--|------------------------------------|----------------------------------|-----|-----|-----|------|------|------|------|------|------|------|------|
| | | 400 | 500 | 600 | 700 | 800 | 900 | 1000 | 1200 | 1400 | 1600 | 1800 | 2000 |
| | | 15 °C (Δt = 65) | 400 | 394 | 492 | 591 | 689 | 788 | 886 | 985 | 1182 | 1379 | 1576 |
| 18 °C (Δt = 62) | 400 | 371 | 463 | 556 | 649 | 741 | 834 | 927 | 1112 | 1297 | 1482 | 1668 | 1853 |
| | 500 | 441 | 552 | 662 | 772 | 883 | 993 | 1103 | 1324 | 1545 | 1765 | 1986 | 2207 |
| | 600 | 512 | 640 | 767 | 895 | 1023 | 1151 | 1279 | 1535 | 1791 | 2047 | 2302 | 2558 |
| 20 °C (Δt = 60) | 400 | 355 | 444 | 533 | 622 | 711 | 799 | 888 | 1066 | 1243 | 1421 | 1599 | 1776 |
| | 500 | 423 | 529 | 635 | 740 | 846 | 952 | 1058 | 1269 | 1481 | 1692 | 1904 | 2115 |
| | 600 | 490 | 613 | 735 | 858 | 980 | 1103 | 1225 | 1470 | 1715 | 1961 | 2206 | 2451 |
| 22 °C (Δt = 58) | 400 | 340 | 425 | 510 | 595 | 680 | 765 | 850 | 1020 | 1190 | 1360 | 1530 | 1700 |
| | 500 | 405 | 506 | 607 | 709 | 810 | 911 | 1012 | 1215 | 1417 | 1620 | 1822 | 2025 |
| | 600 | 469 | 586 | 703 | 820 | 938 | 1055 | 1172 | 1407 | 1641 | 1875 | 2110 | 2344 |
| 24 °C (Δt = 56) | 400 | 325 | 406 | 488 | 569 | 650 | 731 | 813 | 975 | 1138 | 1300 | 1463 | 1625 |
| | 500 | 387 | 484 | 581 | 677 | 774 | 871 | 968 | 1161 | 1355 | 1548 | 1742 | 1935 |
| | 600 | 448 | 560 | 672 | 784 | 896 | 1008 | 1119 | 1343 | 1567 | 1791 | 2015 | 2239 |

11

Watt Heating output
 Inlet temp. **70 °C**
 Outlet temp. **55 °C**

| Room Temp. Темп. среды Temp. zraka (°C) | Height Высота Višina (mm) | Length (mm) | | | | | | | | | | | |
|--|------------------------------------|-----------------------------|-----|-----|-----|-----|-----|------|------|------|------|------|------|
| | | 400 | 500 | 600 | 700 | 800 | 900 | 1000 | 1200 | 1400 | 1600 | 1800 | 2000 |
| | | 15 °C (Δt = 47,5) | 400 | 263 | 329 | 394 | 460 | 526 | 592 | 657 | 789 | 920 | 1052 |
| 18 °C (Δt = 44,5) | 400 | 242 | 302 | 363 | 423 | 484 | 544 | 605 | 726 | 847 | 968 | 1089 | 1210 |
| | 500 | 288 | 360 | 432 | 504 | 575 | 647 | 719 | 863 | 1007 | 1151 | 1295 | 1439 |
| | 600 | 331 | 414 | 497 | 580 | 663 | 746 | 828 | 994 | 1160 | 1325 | 1491 | 1657 |
| 20 °C (Δt = 42,5) | 400 | 228 | 285 | 342 | 399 | 456 | 513 | 570 | 684 | 798 | 912 | 1027 | 1141 |
| | 500 | 271 | 339 | 407 | 475 | 542 | 610 | 678 | 813 | 949 | 1085 | 1220 | 1356 |
| | 600 | 312 | 390 | 468 | 546 | 624 | 702 | 780 | 936 | 1092 | 1248 | 1404 | 1560 |
| 22 °C (Δt = 40,5) | 400 | 214 | 268 | 322 | 375 | 429 | 483 | 536 | 643 | 751 | 858 | 965 | 1072 |
| | 500 | 255 | 319 | 382 | 446 | 510 | 573 | 637 | 764 | 892 | 1019 | 1147 | 1274 |
| | 600 | 293 | 366 | 439 | 513 | 586 | 659 | 732 | 879 | 1025 | 1172 | 1318 | 1464 |
| 24 °C (Δt = 38,5) | 400 | 201 | 251 | 302 | 352 | 402 | 452 | 503 | 603 | 704 | 804 | 905 | 1005 |
| | 500 | 239 | 298 | 358 | 418 | 477 | 537 | 597 | 716 | 835 | 955 | 1074 | 1193 |
| | 600 | 274 | 343 | 411 | 480 | 548 | 617 | 685 | 822 | 959 | 1096 | 1233 | 1370 |

22

Watt Heating output
 Inlet temp. **90 °C**
 Outlet temp. **70 °C**

| Room Temp. Темп. среды Temp. zraka (°C) | Height Высота Višina (mm) | Length (mm) | | | | | | | | | | | |
|--|------------------------------------|---------------------------|------|------|------|------|------|------|------|------|------|------|------|
| | | 400 | 500 | 600 | 700 | 800 | 900 | 1000 | 1200 | 1400 | 1600 | 1800 | 2000 |
| | | 15 °C (Δt = 65) | 300 | - | - | 826 | 963 | 1101 | 1239 | 1376 | 1652 | 1927 | 2202 |
| 18 °C (Δt = 62) | 400 | - | - | 1044 | 1218 | 1392 | 1566 | 1740 | 2089 | 2437 | 2785 | 3133 | 3481 |
| | 500 | 852 | 1065 | 1278 | 1490 | 1703 | 1916 | 2129 | 2555 | 2981 | 3407 | 3833 | 4258 |
| | 600 | 1033 | 1291 | 1549 | 1808 | 2066 | 2324 | 2582 | 3099 | 3615 | 4131 | 4648 | 5164 |
| 20 °C (Δt = 60) | 300 | - | - | 776 | 906 | 1035 | 1164 | 1294 | 1552 | 1811 | 2070 | 2329 | 2587 |
| | 400 | - | - | 981 | 1145 | 1308 | 1472 | 1635 | 1962 | 2289 | 2616 | 2943 | 3270 |
| | 500 | 800 | 1000 | 1200 | 1400 | 1600 | 1800 | 1999 | 2399 | 2799 | 3199 | 3599 | 3999 |
| 600 | 969 | 1211 | 1454 | 1696 | 1938 | 2180 | 2423 | 2907 | 3392 | 3876 | 4361 | 4845 | |
| 22 °C (Δt = 58) | 300 | - | - | 744 | 868 | 991 | 1115 | 1239 | 1487 | 1735 | 1983 | 2231 | 2479 |
| | 400 | - | - | 940 | 1096 | 1253 | 1409 | 1566 | 1879 | 2192 | 2506 | 2819 | 3132 |
| | 500 | 766 | 957 | 1149 | 1340 | 1531 | 1723 | 1914 | 2297 | 2680 | 3063 | 3446 | 3828 |
| 600 | 927 | 1159 | 1391 | 1622 | 1854 | 2086 | 2318 | 2781 | 3245 | 3708 | 4172 | 4635 | |
| 24 °C (Δt = 56) | 300 | - | - | 711 | 830 | 948 | 1067 | 1185 | 1423 | 1660 | 1897 | 2134 | 2371 |
| | 400 | - | - | 898 | 1048 | 1198 | 1348 | 1497 | 1797 | 2096 | 2396 | 2695 | 2995 |
| | 500 | 732 | 915 | 1098 | 1281 | 1464 | 1647 | 1830 | 2196 | 2562 | 2928 | 3294 | 3660 |
| 600 | 886 | 1107 | 1328 | 1550 | 1771 | 1993 | 2214 | 2657 | 3100 | 3542 | 3985 | 4428 | |

22

Watt Heating output
 Inlet temp. **70 °C**
 Outlet temp. **55 °C**

| Room Temp. Темп. среды Temp. zraka (°C) | Height Высота Višina (mm) | Length (mm) | | | | | | | | | | | |
|--|------------------------------------|-----------------------------|-----|------|------|------|------|------|------|------|------|------|------|
| | | 400 | 500 | 600 | 700 | 800 | 900 | 1000 | 1200 | 1400 | 1600 | 1800 | 2000 |
| | | 15 °C (Δt = 47,5) | 300 | - | - | 548 | 639 | 730 | 821 | 913 | 1095 | 1278 | 1460 |
| 18 °C (Δt = 44,5) | 400 | - | - | 690 | 805 | 920 | 1035 | 1150 | 1380 | 1611 | 1841 | 2071 | 2301 |
| | 500 | 561 | 701 | 842 | 982 | 1122 | 1263 | 1403 | 1684 | 1964 | 2245 | 2525 | 2806 |
| | 600 | 676 | 845 | 1014 | 1184 | 1353 | 1522 | 1691 | 2029 | 2367 | 2705 | 3043 | 3382 |
| 20 °C (Δt = 42,5) | 300 | - | - | 503 | 586 | 670 | 754 | 838 | 1005 | 1173 | 1341 | 1508 | 1676 |
| | 400 | - | - | 633 | 739 | 844 | 950 | 1055 | 1267 | 1478 | 1689 | 1900 | 2111 |
| | 500 | 515 | 643 | 772 | 900 | 1029 | 1158 | 1286 | 1544 | 1801 | 2058 | 2315 | 2573 |
| 600 | 619 | 774 | 929 | 1084 | 1239 | 1393 | 1548 | 1858 | 2168 | 2477 | 2787 | 3096 | |
| 22 °C (Δt = 40,5) | 300 | - | - | 473 | 552 | 631 | 710 | 789 | 947 | 1104 | 1262 | 1420 | 1578 |
| | 400 | - | - | 596 | 695 | 795 | 894 | 993 | 1192 | 1391 | 1589 | 1788 | 1987 |
| | 500 | 484 | 605 | 726 | 847 | 968 | 1089 | 1210 | 1452 | 1694 | 1936 | 2178 | 2420 |
| 600 | 582 | 728 | 873 | 1019 | 1164 | 1310 | 1455 | 1746 | 2037 | 2328 | 2619 | 2910 | |
| 24 °C (Δt = 38,5) | 300 | - | - | 444 | 518 | 592 | 667 | 741 | 889 | 1037 | 1185 | 1333 | 1481 |
| | 400 | - | - | 559 | 652 | 746 | 839 | 932 | 1119 | 1305 | 1491 | 1678 | 1864 |
| | 500 | 454 | 567 | 681 | 794 | 908 | 1021 | 1135 | 1362 | 1589 | 1816 | 2043 | 2270 |
| 600 | 545 | 682 | 818 | 954 | 1091 | 1227 | 1363 | 1636 | 1909 | 2181 | 2454 | 2727 | |



NIKO HEATING

Niko Bathrooms

Unit 5
Broomhill Business Complex,
Tallaght,
D24X270

T: (01) 400 0000

E: sales@nikobathrooms.ie

www.nikobathrooms.ie

